

phantomlab

Magphan® RT Phantom Product Guide

Copyright © 2024

WARNING

To avoid phantom damage:

- This phantom should be stored at room temperature. Do not allow this phantom to be frozen or subjected to high heat. If this phantom is frozen the housing and spheres will be damaged beyond repair.
- This phantom is not intended to be shipped from site to site. If you have to ship the phantom you must remove 150cc of fill solution from the phantom before replacing the fill plug. If the phantom is shipped without removing fill solution expansion of the fill solution could result in phantom damage.

To avoid fire:

- This product has an FH3-4 mm/min flame rating and is considered to be flammable. It is advised not to expose this product to open flame or high temperature (over 125° Celsius or 250° Fahrenheit) heating elements.

Disregarding these warnings will nullify the Warranty.

TMR022 TMR033
TMR050 TMR056

Medical device labeling

Manufactured by: Phantom Laboratory
 2727 State Route 29
 Greenwich, NY 12834 USA



EU Representative: Hoff & Lowendahl AB
 Eudamed Actor ID: SE-AR-000001888
 Address: Högåsvägen , 125 74141 Knivsta
 Telephone number: +46 (0) 722313355
 Email: info@lowendahl.eu



Product: Magphan® RT



Model: TMR022



UDI:



(01)00812266030840

Basic UDI: B-TMR022J6



Model: TMR033



UDI:



(01)00812266030864

Basic UDI: B-TMR033JB



Model: TMR050



UDI:



(01)00812266030857

Basic UDI: B-TMR050JB



Model: TMR056



UDI:



(01)00812266031298

Basic UDI: B-TMR056JP

Device Class: 1



This device is intended for use under direction of a trained medical physicist. Please refer to your machine manufacturer documentation and regulatory guidance for information on intended use.

A sample of this product has been assessed against the Essential Requirements of the EU Medical Device Regulation (MDR). The above mentioned product is deemed in compliance with MDR 2017/745 EU.

A risk assessment was conducted to the following standard: EN ISO14971
This declaration of conformity is the result of testing and evaluation performed by Phantom Laboratory.

phantomlab

Magphan® RT Phantom Product Guide

Contents

Warning	1
Introduction	5
Fill Solution	6
Unpacking and topping off the phantom	7
Drawings	9
Phantom test components	10
Magphan® RT 1090 Contrast Spheres	13
Positioning the phantom components on the table for scanning	14
Disassembling the phantom and removing it from the table	18
Scanning the phantom	18
Analyzing the phantom images with the Smári service	19
Warranty	20

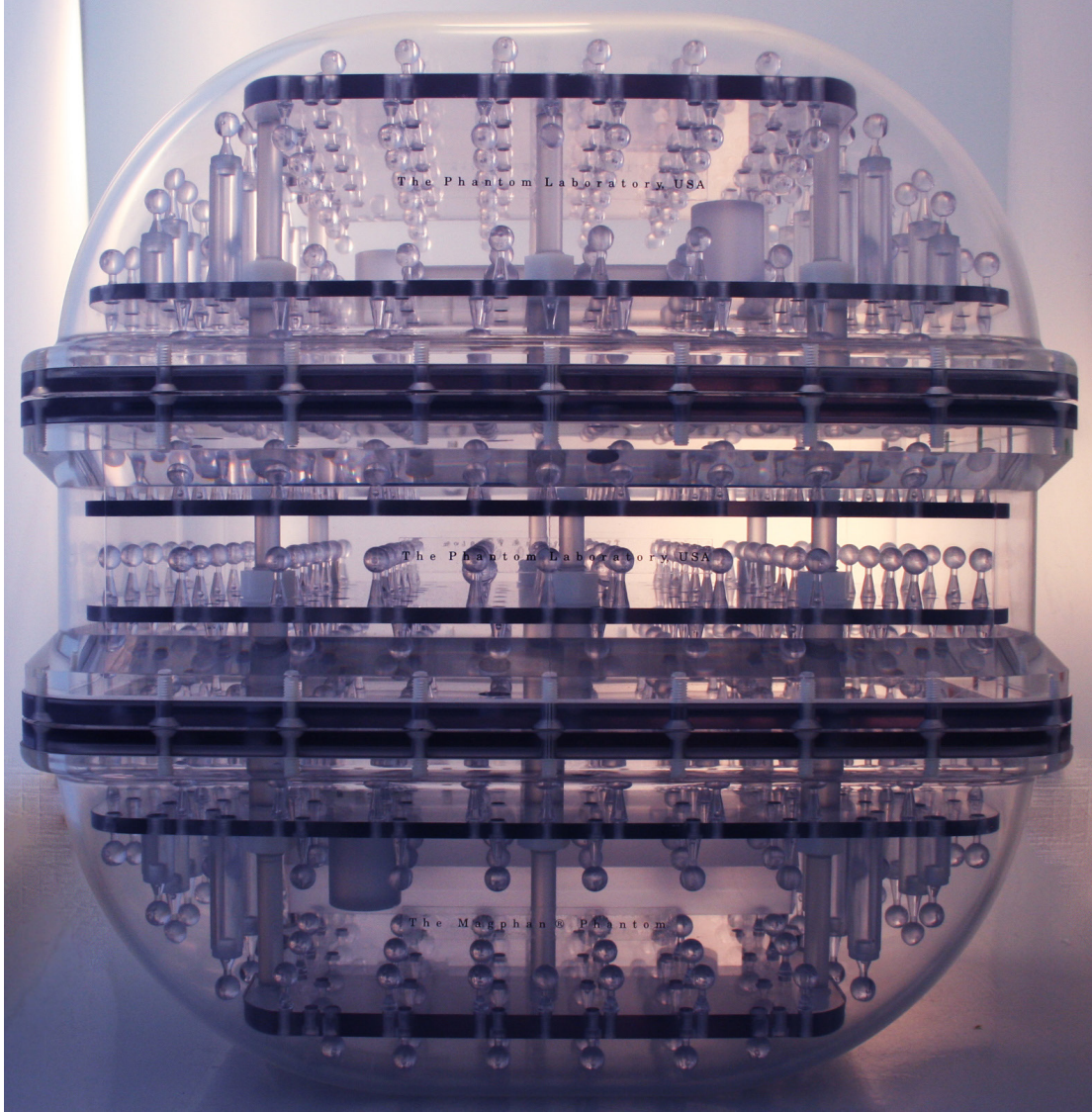

Magphan® RT TMR033

Introduction

Richard Mallozzi, Ph.D., leads Phantom Laboratory's development of the Magphan® RT. The Magphan® RT addresses the needs of medical physicists that use MR in their treatment planning and/or position verification for radiation therapy, surgery or modeling applications.

The phantom is designed to be used with the Smári analysis service. The first two years of the service are included with the phantom purchase.

We do not make specific recommendations on the content of your quality assurance program because each organization has its own unique set of requirements.

If you have any additional questions please contact Phantom Laboratory at:

Phone: 800-525-1190 or 518-692-1190

email: sales@phantomlab.com

Additional product information is available at: www.phantomlab.com

Fill Solution

The TMR022 and TMR033 contain approximately 16 and 23 liters of solution respectively. The background solution has T1 and T2 values between 350-400 ms at 1.5 Tesla. These properties are dependent upon field strength, and would be expected to fall in the 175-225 ms range at 0.35 Tesla, and 500-550 ms at 3.0 Tesla.

The water based solution has the following materials.

Percentage by weight

96.4% Distilled water

2.5% PVP (thickens the solution to reduce fluid flow, used in cosmetics)

0.9% Sodium Chloride (to mimic human tissue salinity)

< 0.2% Potassium Sorbate (prevents bacterial growth, used in beer and milk)

< 0.2% Copper Sulfate (to shorten T1, see SDS)

< 0.2% Blue Food Color (it looks pretty)

The fill solution is made by dissolving powders into distilled water. The SDS sheets for these materials that were used at the time this manual was assembled are available from from their respective suppliers:

Sodium Chloride-

<http://www.sigmaaldrich.com/MSDS/MSDS/DisplayMSDSPage.do?country=US&language=en&productNumber=746398&brand=SIGALD&PageToGoToURL=http%3A%2F%2Fwww.sigmaaldrich.com%2Fcatalog%2Fsearch%3Finterface%3DAll%26term%3D746398-1kg%26N%3D0%26focus%3Dproduct%26lang%3Den%26region%3DUS>

PVP40

<http://www.sigmaaldrich.com/MSDS/MSDS/DisplayMSDSPage.do?country=US&language=en&productNumber=PVP40&brand=SIAL&PageToGoToURL=http%3A%2F%2Fwww.sigmaaldrich.com%2Fcatalog%2Fsearch%3Fterm%3DPVP40-5Kg%26interface%3DAll%26N%3D0%26mode%3Dmatch%2520partialmax%26lang%3Den%26region%3DUS%26focus%3Dproduct>

Copper (II) Sulfate Pentahydrate, 99%

<https://www.alfa.com/en/content/msds/USA/A11262.pdf>

Potassium sorbate, 99%

<https://www.alfa.com/en/content/msds/USA/A12844.pdf>

Unpacking and topping off the phantom

The Magphan® RT is shipped in multiple boxes. As soon as the phantom is received it should be placed in a room temperature location. Carefully open the boxes and remove the phantom cases. An additional cardboard box contains topping-off fill solution. The cases use stainless steel, plastic or aluminum hardware so they can be stored in the magnet room.

To open a case, release the two latches on the front, lift the lid and pull the front panel down so it rests flat on the surface the box is sitting on. Then slide the phantom forward over the front panel. This will make it easier to get your hands under the phantom so it can be securely held when moving.

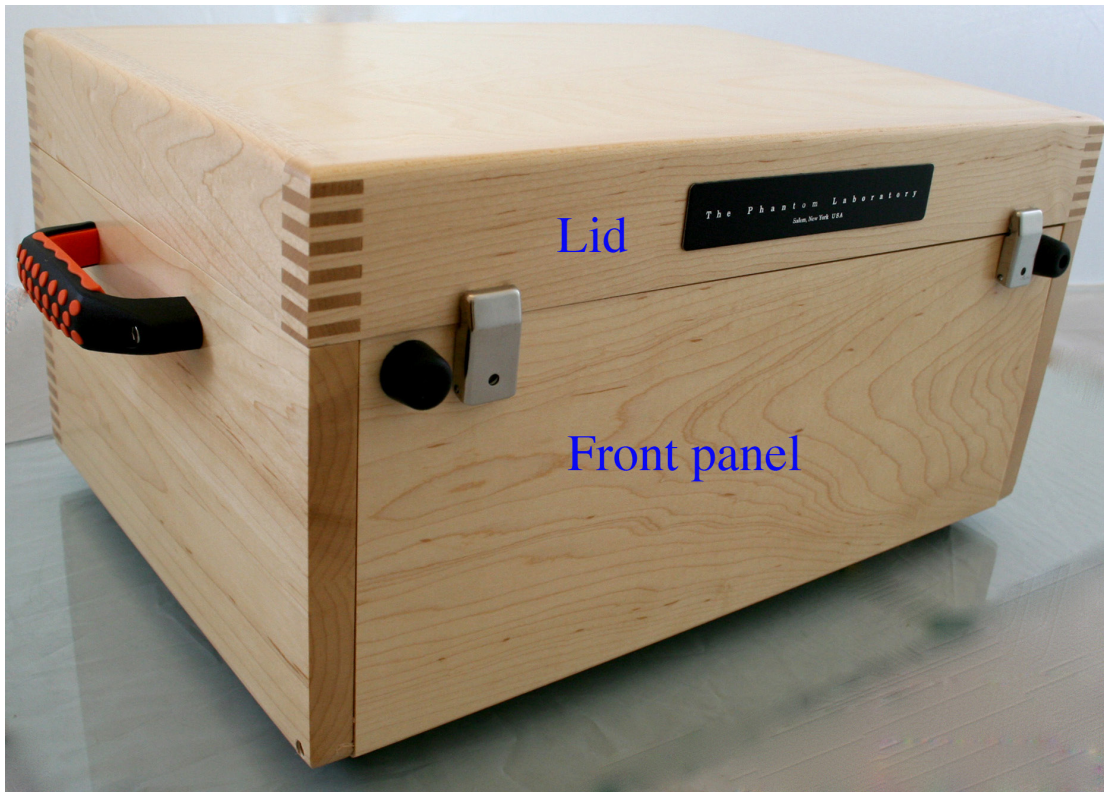

Note: orange handle indicates the phantom base.

The phantoms are bagged and wrapped with aluminum foil to help reduce heating and cooling effects during transport. Once the phantom is received the plastic bags and aluminum foil wrapping can be recycled. If there is liquid in the bag, contact Phantom Laboratory at info@phantomlab.com or 518-692-1190.

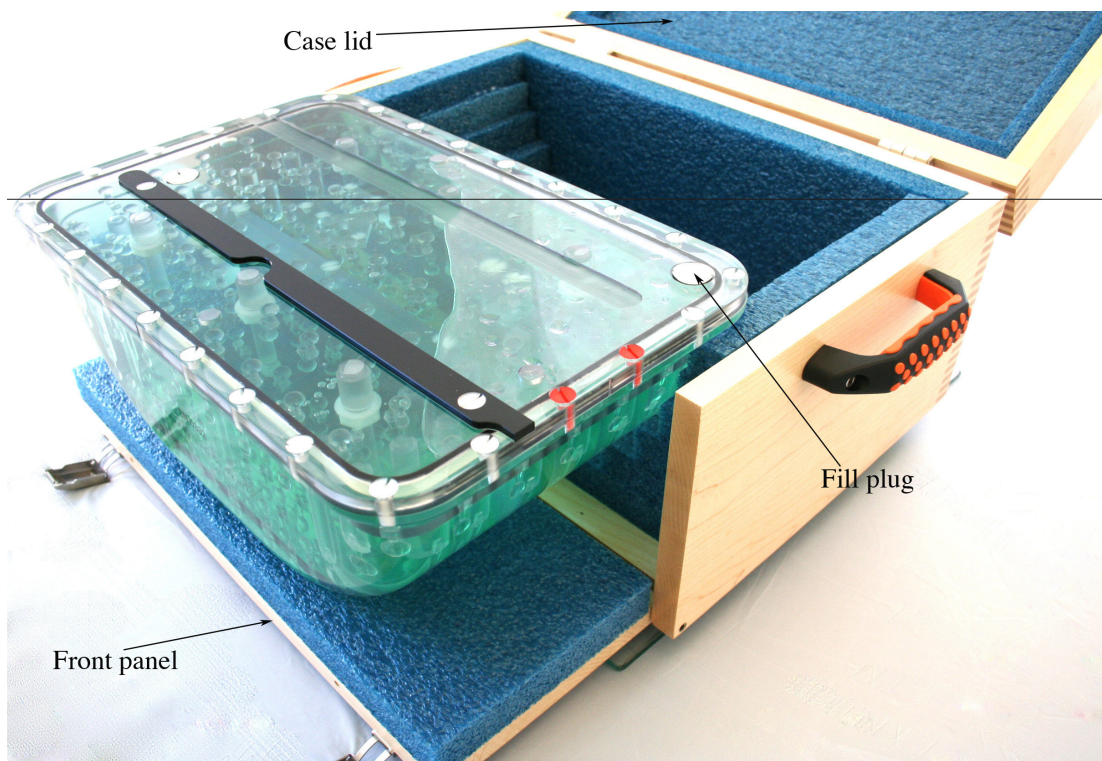

Each section of the phantom is purposely shipped with approximately 150 ml of fill solution removed. Replacement solution is shipped in plastic bottles along with the phantom. After the phantoms reach room temperature the sections will need to be topped off. Use foam wedges or towels to slightly elevate the corner of the phantom with the fill plug. Remove the fill plug and use the supplied syringe to transfer fill solution from the bottles to the phantom sections.

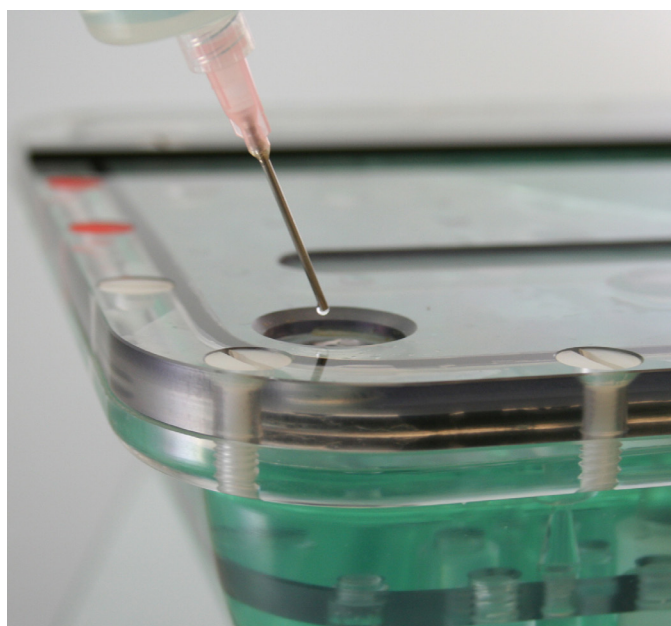

After filling, reinstall the fill plug (flat head screw with o-ring) to seal the phantom. If additional air appears in a section it may need to be topped off again. However, if a section leaks fluid, contact Phantom Laboratory. Once the phantom is filled you are ready to scan. The remaining refill fluid should be saved to top-off the phantom in the future if air bubbles should develop.

Drawings

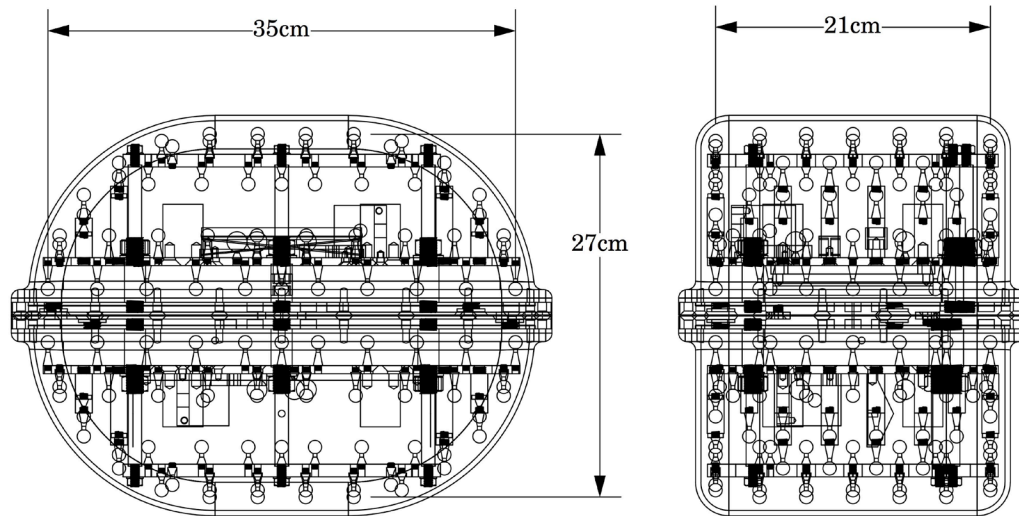

Magphan® RT 820 TMR022

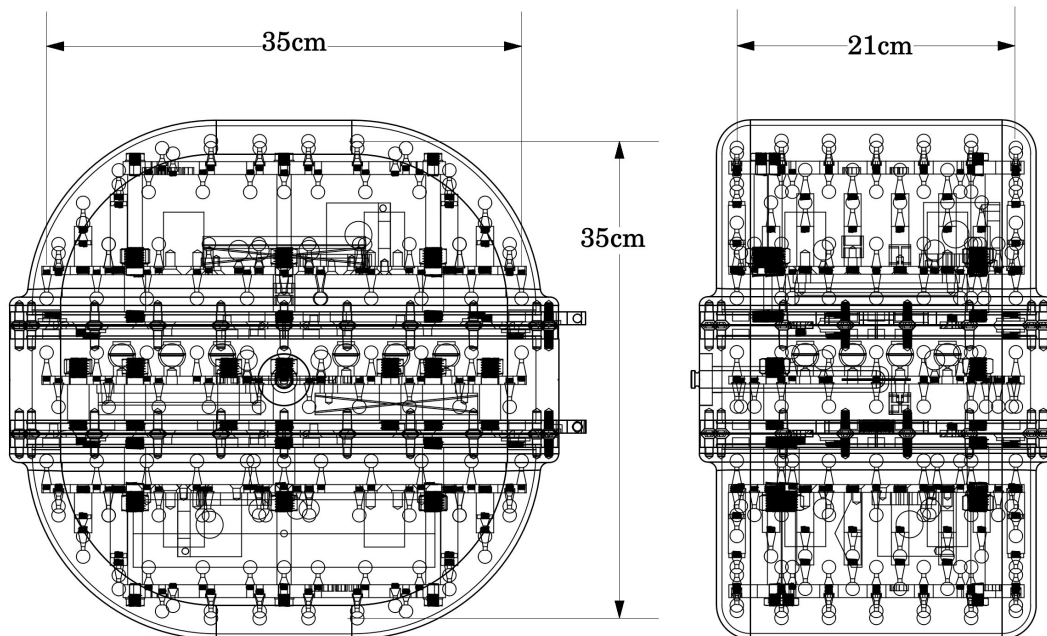

Magphan® RT 1090 and 1090D TMR056 and TMR050

Magphan® RT 820, 1090 and 1230 configurations share the same top and bottom section. The Magphan® RT 1090D and 1090 have the TMR047 (1090D) or TMR057 (1090) center section. The difference between the Magphan® RT 1090D TMR050 and the Magphan® RT 1090 TMR056 is the 1090D has a central cavity for the insertion of a dose measurement chamber. The components of these sections are illustrated on the following pages.

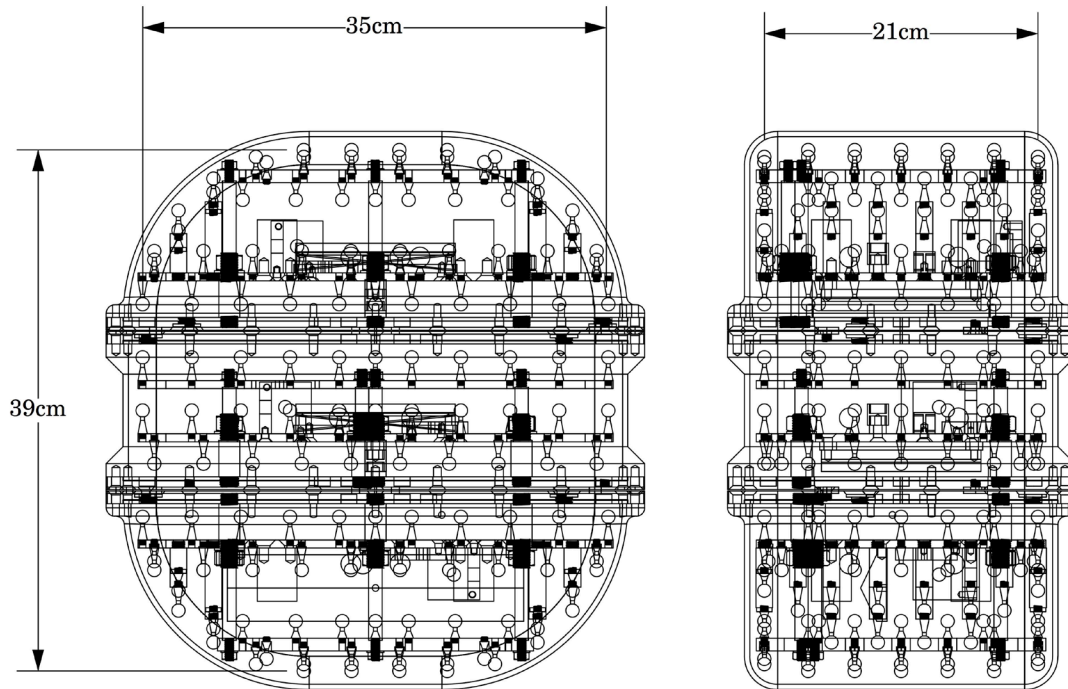

Magphan® RT 1230 TMR033

Magphan® RT 820, 1090 and 1230 configurations share the same top and bottom section. The Magphan® RT 1230 has the additional TMR008 center section. The components of these sections are illustrated on the following pages.

Phantom test components

The phantom consists of a uniform background fill with solid test components that appear dark in MR images. Below is a list of test components in the phantom:

- Fiducial spheres for distortion measurement

- Three slice thickness ramp pairs -- one for each of the cardinal slice orientations (axial, sagittal, coronal)

- Three MTF apertures for measuring the Modulation Transfer Function (resolution) in each of the cardinal slice orientations

- Two noise rods for measuring noise

- Ghosting holes for possible future ghosting measurements

- A slice profile block for possible future measurement of the spatial dependence of the slice profile

The TMR047 and TMR057 central sections of the 1090D and 1090 contain an array of 24 contrast spheres with inner diameter 1.7 cm, filled with solutions covering a range of T1, T2, and ADC values.

TMR009 Top Section Assembly

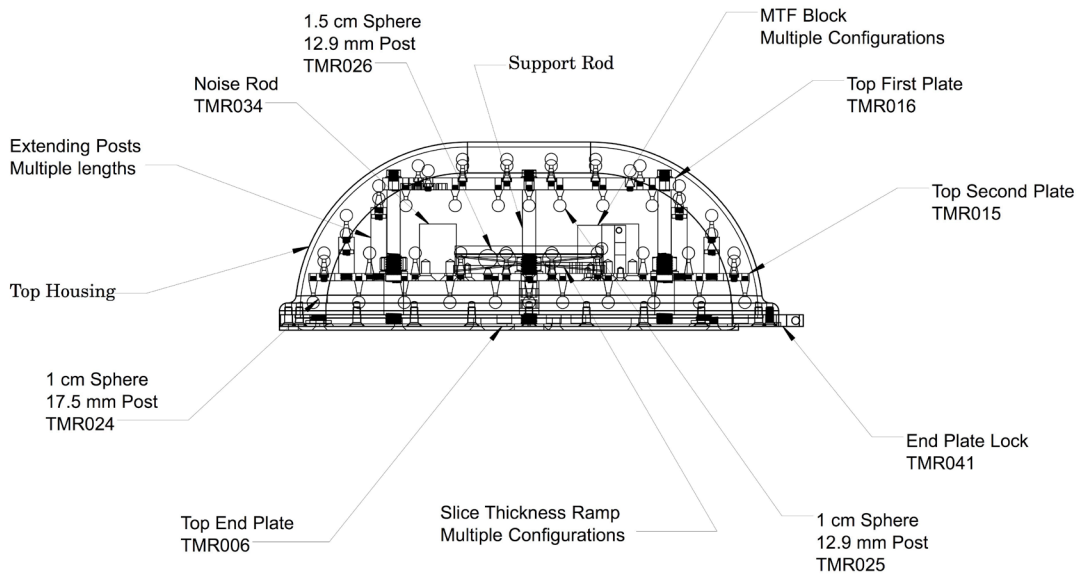

TMR047 and TMR057 Center Section Assembly

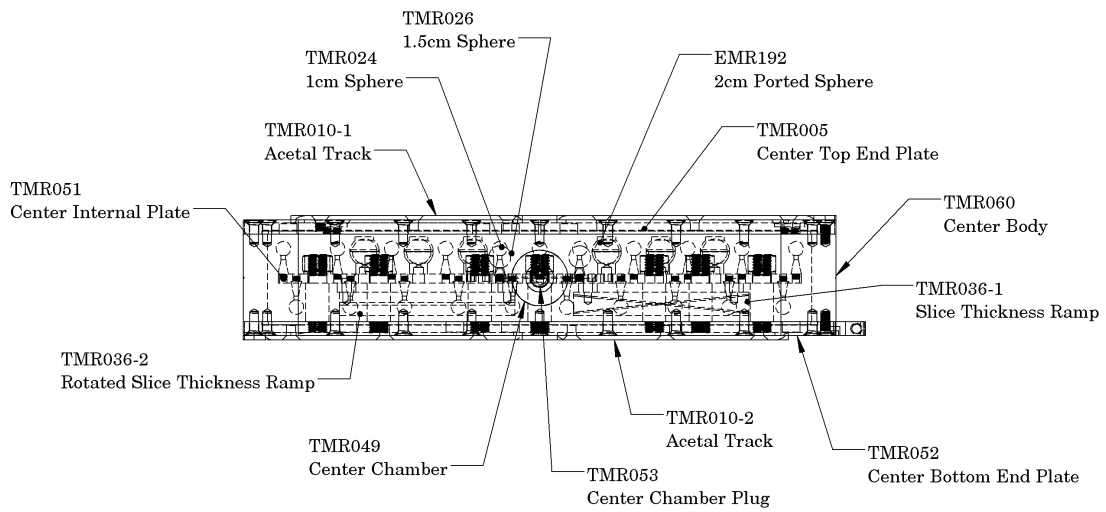

TMR008 Center Section Assembly

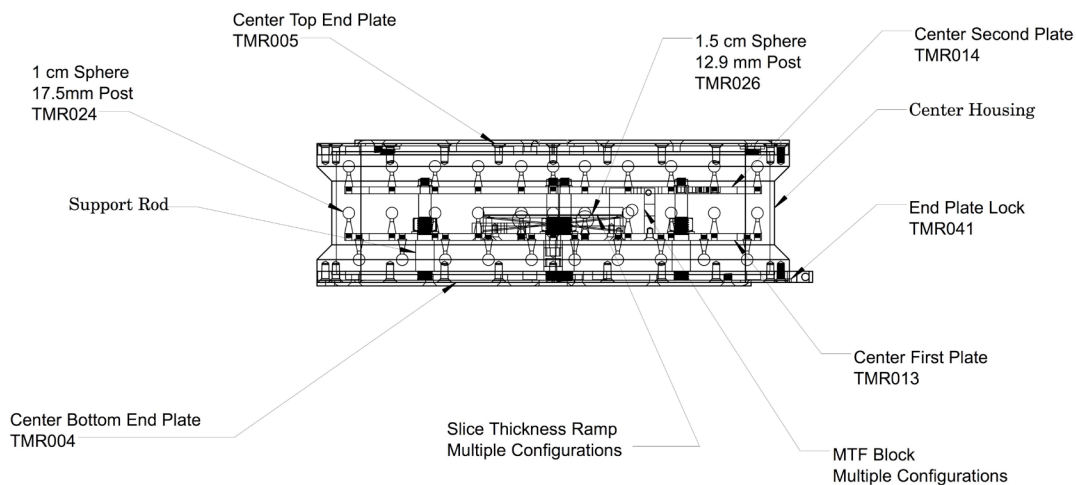

TMR007 Bottom Section Assembly

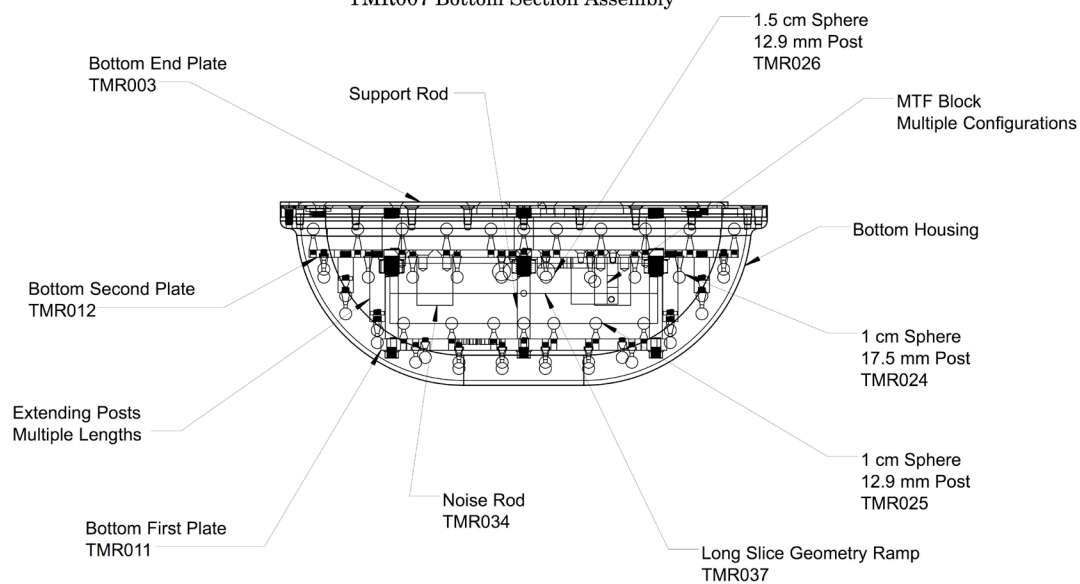

Magphan® RT 1090 Contrast Spheres

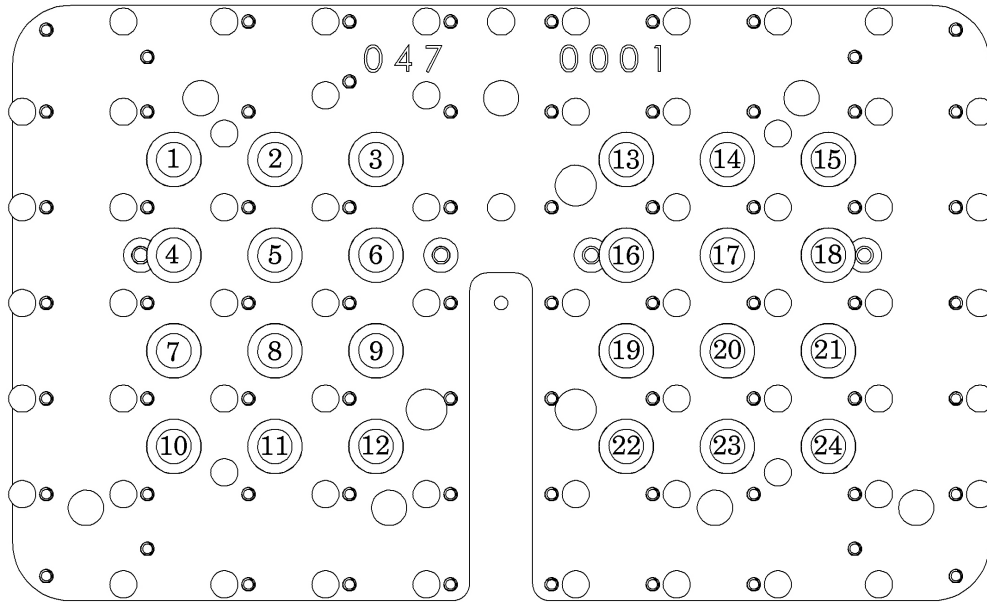

The 24 Contrast spheres contain 12 distinct solutions with the following target values.

Position Number	T1 Target	T2 Target	ADC Target
1	813	146	2
2	981	191	2.5
3	220	22	2.5
4	1182	675	1.5
5	265	111	0.75
6	560	65	2.5
7	265	29	2.5
8	385	49	2.5
9	2350	2000	2.5
10	320	38	2.5
11	675	85	2.5
12	464	111	1
13	464	111	1
14	675	85	2.5
15	320	38	2.5
16	2350	2000	2.5
17	385	49	2.5
18	265	29	2.5
19	560	65	2.5
20	265	111	0.75
21	1182	675	1.5
22	220	22	2.5
23	981	191	2.5
24	813	146	2

Positioning the phantom components on the table for scanning

Warning:

Do Not Move the assembled sections of the phantom together. Always move the phantom one section at a time. This will prevent exposure to excessive weight and stress on the phantom.

The Magphan® RT 820 has 2 sections and the 1230 has 3 sections. Each section comes with its own case. The handles are color coded to help identify the sections. The bottom section case has orange handles, the middle section case has grey handles, and top case has yellow handles.



Yellow handle, Top, TMR009

Grey handle, Middle, TMR008 (Magphan® RT 1230 only)

Orange handle, Bottom, TMR007

If you have a Magphan® RT 1230 you have the option of not using the middle section and configuring it as a Magphan® RT 820.

Assemble the phantom one section at a time on the scanner couch starting with the Bottom section TMR007. Note: the 2 orange screws should be away from you.

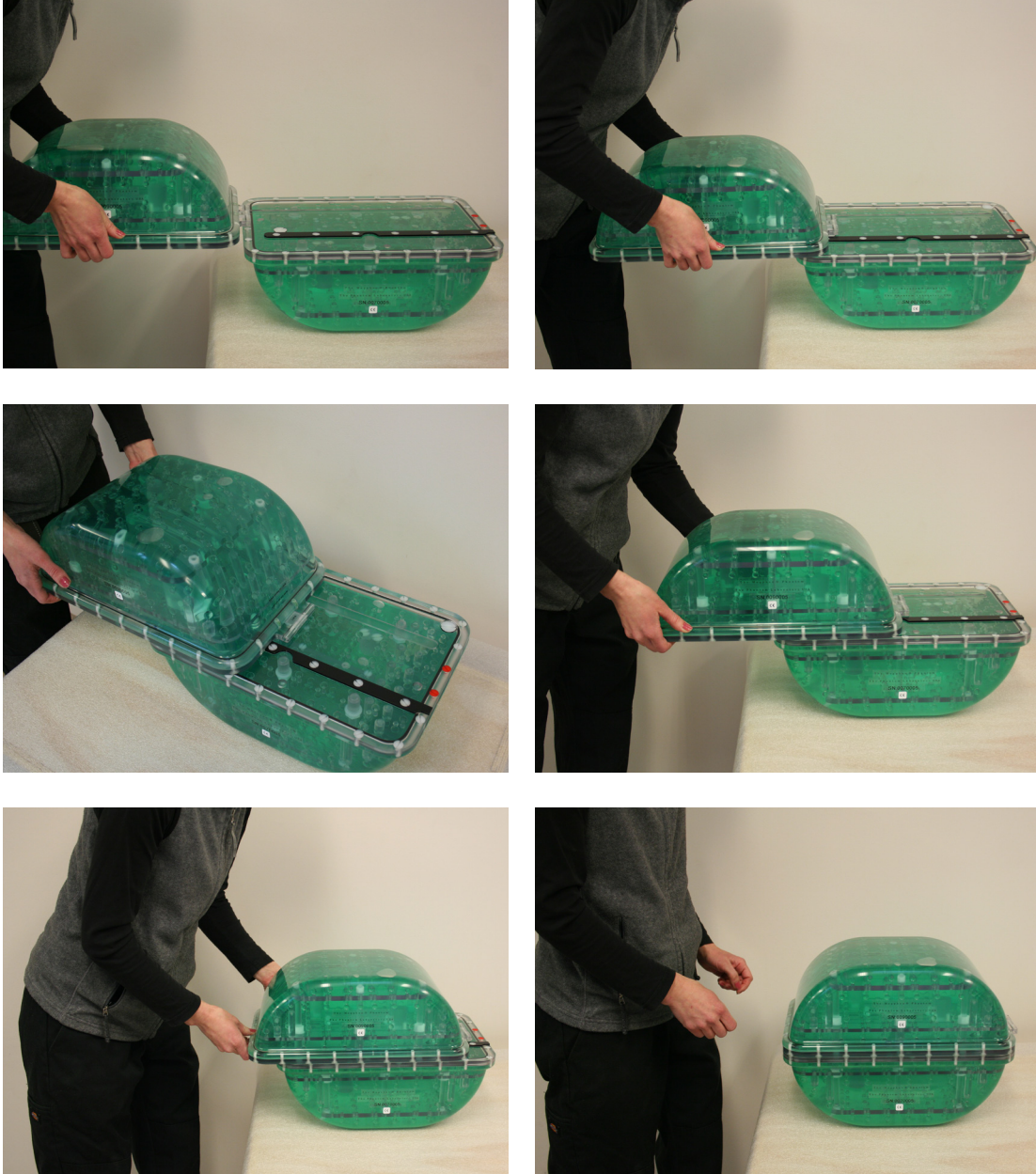

The Images above show the Magphan® RT 820 configuration In assembling the Magphan® RT 1230 the TMR008 middle section is added to the assembly

Align the dovetail tracks on the top and bottom sections and slide the top section onto the bottom section. The phantom should slide easily on the tracks. Slide the phantom all the way to the end of the track.

A locking mechanism is located on the end of the phantom with the colored screws. After sliding the sections together the lock should be pressed down to prevent the sections from sliding apart.

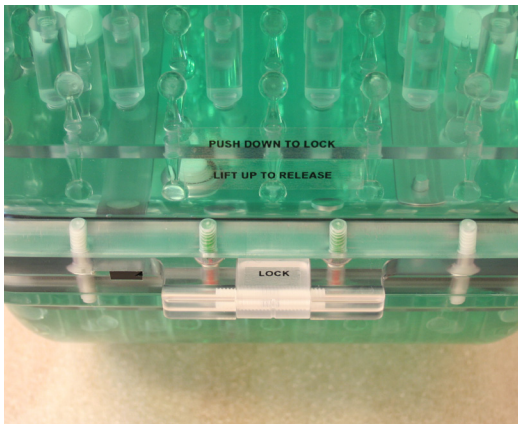

Lock mechanism



Press down back of tab to lock

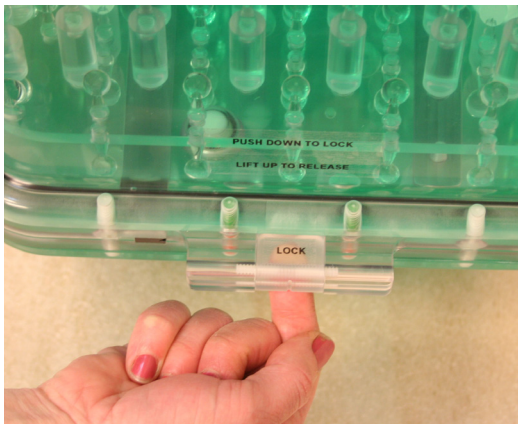

Lift back of tab to release, then the top section can be slid off the lower section

Note: If the top section is not all the way at the end of the track the lock will not be able to be pressed down.

Accurate alignment is not critical for the distortion measurements, however the slice thickness and resolution measurements will only be performed if the phantom alignment falls within two degrees of its intended orientation, or from a configuration rotated by 90 degrees about a vertical axis from its intended configuration.

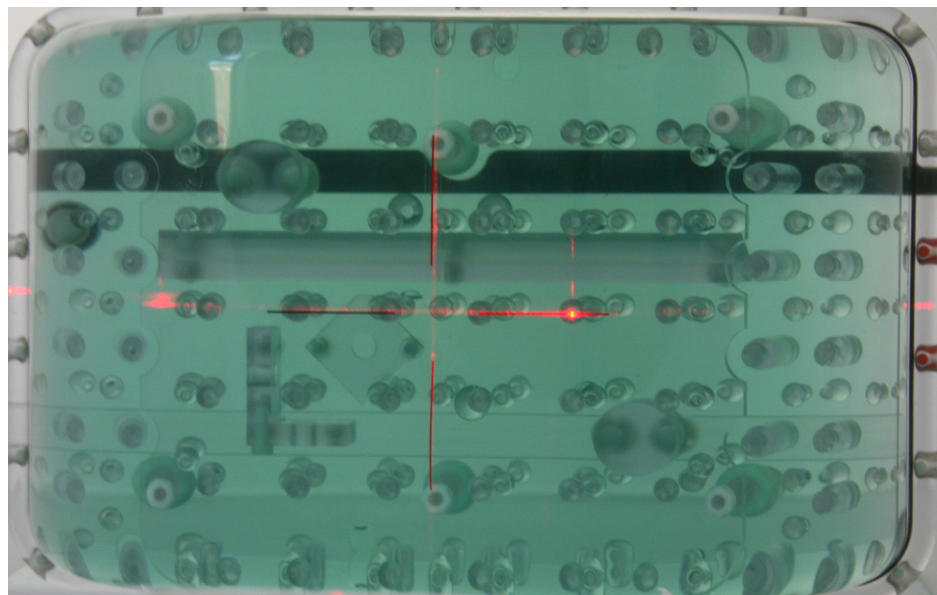
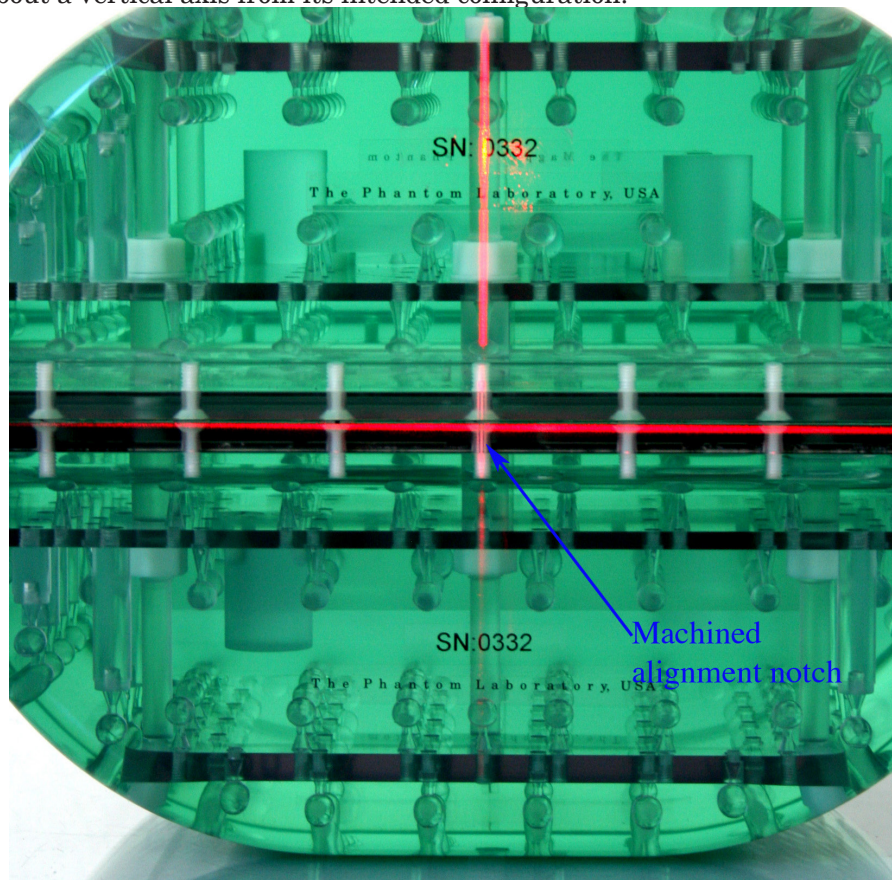

View of machined alignment notches on side of phantom and labels on the top of phantom

After the phantom is assembled on the table recheck the alignment using the laser lights. The grooves on the sides and ends can be used to verify alignment. Additionally, there are black line decals on the top to assist in positioning. If using a torso array, it may be necessary to landmark the phantom prior to placing the top half of the array on the phantom.

Disassembling the phantom and removing it from the table

WARNING: Do not remove the phantom from the table as a single assembly.

Stand on the side of the patient table opposite the green and orange screws in the phantom. Release the slide lock and carefully slide the top section toward you making sure to support it so you do not rock or drop the phantom. Once the section is slid off the end of the tracks carry it to its storage case. Repeat this step with the Magphan® RT 1230 configuration and remove the middle section. Then place the sections in their cases.

Scanning the phantom

The phantom is designed to support a wide range of scanning protocols, and is meant to provide information on the specific protocols being used clinically, rather than a predefined set of test protocols. For the analysis to function properly some prerequisites need to be met. The Signal-to-Noise ratio must be sufficiently high for the slice thickness and resolution measurements to process (approximately 20:1 or higher for mean/standard deviation). This requirement is assessed automatically during the Image Owl analysis processing. The images must also have relatively low artifacts.

Most conventional MR images meet these requirements, but some advanced sequences such as Echo Planar Imaging can have high sensitivity to magnetic field inhomogeneities that can introduce strong artifacts into the images. Artifacts have potential to render the analysis unable to properly locate the phantom features within the images. If artifacts appear to be a problem, possible recourses are to consult an MRI physicist or the manufacturer of the equipment to understand if the artifacts are expected from the particular set of acquisition parameters, or if there is a service issue that needs to be addressed.

Analyzing the phantom images with the Smári service

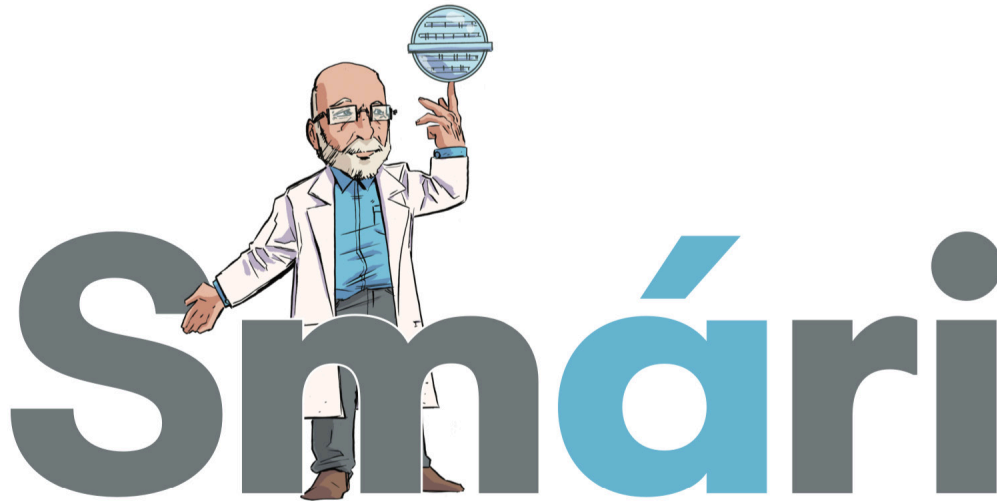

The Magphan® RT purchase includes 2 years of the Smári analysis service

Your phantom serial number, which is located on the phantom, is required for registration.

To register for the service, go to the Smári page at our website: phantomlab.com and click on the “Register Your Phantom” button and fill out the form.

Once we receive your information, Phantom Laboratory support will contact you and set up your account.

WARRANTY

PHANTOM LABORATORY (“Seller”) warrants that this product shall remain in good working order and free of all material defects for a period of one (1) year following the date of purchase. If, prior to the expiration of the one (1) year warranty period, the product becomes defective, Buyer shall return the product to the Seller at:

By Truck

Phantom Laboratory
2727 State Route 29
Greenwich, NY12834

By Mail

Phantom Laboratory
PO Box 511
Salem, NY 12865-0511

Seller shall, at Seller’s sole option, repair or replace the defective product. The Warranty does not cover damage to the product resulting from accident or misuse.

IF THE PRODUCT IS NOT IN GOOD WORKING ORDER AS WARRANTED, THE SOLE AND EXCLUSIVE REMEDY SHALL BE REPAIR OR REPLACEMENT, AT SELLER’S OPTION. IN NO EVENT SHALL SELLER BE LIABLE FOR ANY DAMAGES IN EXCESS OF THE PURCHASE PRICE OF THE PRODUCT. THIS LIMITATION APPLIES TO DAMAGES OF ANY KIND, INCLUDING, BUT NOT LIMITED TO, DIRECT OR INDIRECT DAMAGES, LOST PROFITS, OR OTHER SPECIAL, INCIDENTAL, OR CONSEQUENTIAL DAMAGES, WHETHER FOR BREACH OF CONTRACT, TORT OR OTHERWISE, OR WHETHER ARISING OUT OF THE USE OF OR INABILITY TO USE THE PRODUCT. ALL OTHER EXPRESS OR IMPLIED WARRANTIES, INCLUDING, BUT NOT LIMITED TO, THE IMPLIED WARRANTY OF MERCHANT ABILITY AND FITNESS FOR PARTICULAR PURPOSE, ARE HEREBY DISCLAIMED.