

**ECT Line Source Phantom SMR355 M a n u a l**

Copyright © 2010

**WARNING**

1. The use of this phantom requires radioactive fill solutions. Only people trained in the safe handling of these materials following all applicable safety requirements should fill and use this phantom.
2. When inserting the Specphan® end plate, follow the instructions listed in this manual. Do not use the nylon screws to set in lid.
3. To prevent damage to your Specphan™ do not let it freeze when filled with a solution.
4. The SMR352 Line Sources are cast from clear urethane which can soften at temperatures over 60°C (140°F). When mounted inside an empty tank that is on its side and exposed to high temperatures the line sources can droop and deform.
5. This product has an FH3-4 mm/min flame rating and is considered to be flammable. It is advised not to expose this product to open flame or high temperature (over 125° Celsius or 250° Fahrenheit) heating elements.

**SMR355**



**ECT Line Source Phantom M a n u a l**

Warning	1
Introduction	4
ECT Line Source Phantom Description	5
Filling the line sources	6
Phantom positioning for scanning	8
Bibliography	9
Warranty	10

## **Introduction**

This phantom has been developed in conjunction with Steve Dyer MHS, for the purpose of monitoring image quality for emission tomography (ECT) systems. It can be used in the application of both manual and automated types of image evaluation.

Because each medical imaging facility has its own unique set of requirements, we do not make specific recommendations on the content of your quality assurance program. This manual includes proposed solutions and test parameters to give you ideas for possible program content. We suggest a review of local governing regulations, manufacturer's specifications, and the needs of your clinicians and physicists before developing your SPECT quality assurance program.

## ECT Line Source Phantom Description

The ECT Line Source Phantom is a cylindrical, liquid filled container with 3 line source inserts.

The phantom enables some flexibility in its configuration. There are 4 threaded holes that can each hold the line source inserts in central or offset positions. There are also blank SMR168 plugs for use when a larger uniformity area is desired.

Overall dimensions:

Diameter	20.3cm ID, 22.2cm OD
Length	20.0cm ID, 23.2cm OD

Composition:

Acrylic housing and acrylic and polycarbonate inserts (liquid filled)  
SMR352 Line Sources are cast from clear urethane

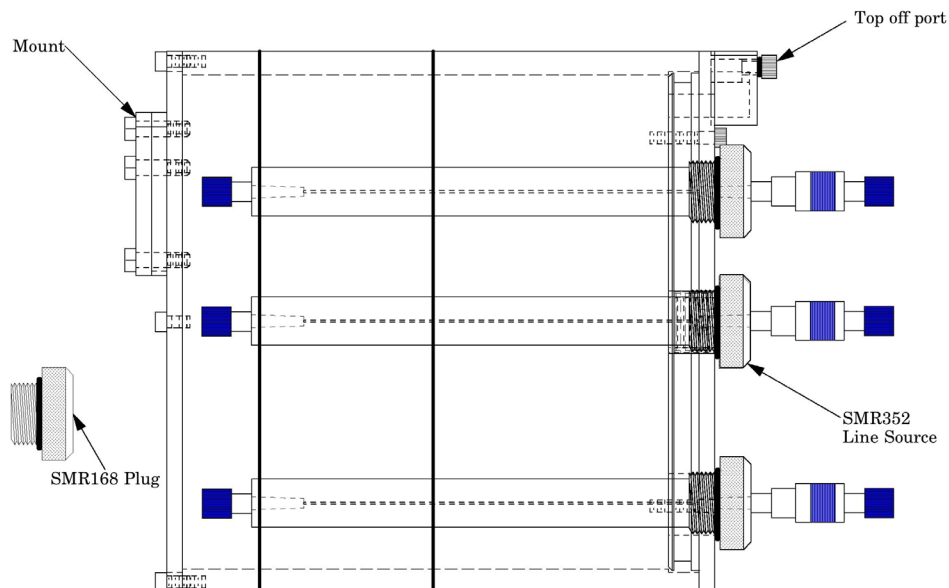

ECT Line Source Phantom

### Filling the line sources

The line sources must be removed from the phantom before filling.

Carefully fill a syringe with a concentrated solution of  $^{99m}\text{Tc}$  or (18F). If any dilution of the solution is required or if any coloring dye is added make sure the solution is well mixed. Adding dye to the solution makes it easier to view the filling process. With the needle removed attach the syringe on the luer of the line source. Inject approximately 0.13cc into the line source with the opposite end open. Then remove the syringe and attach an empty syringe with the plunger about half way removed.

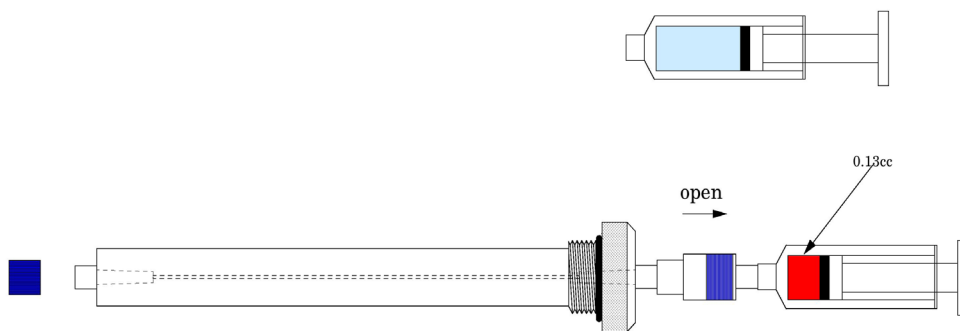

1. Remove the end cap and open the valve on the line source. With the needle removed attach the syringe on the luer of the line source. Inject approximately 0.13cc into the line source with the opposite end open.

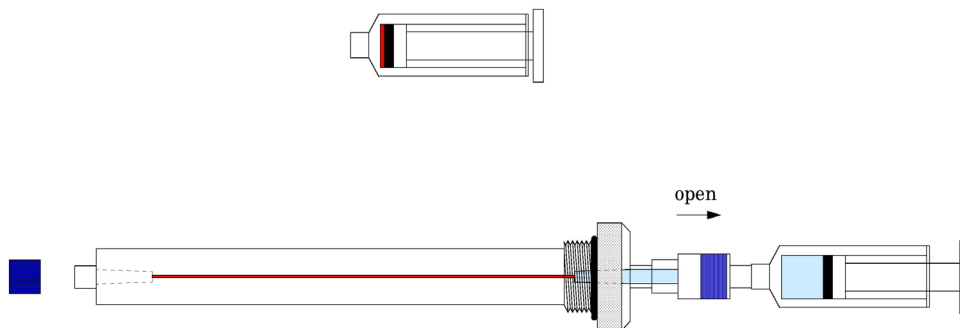

2. Inject air to push the solution through until it fills the effective imaging section of the line source.

Step 3 on next page.

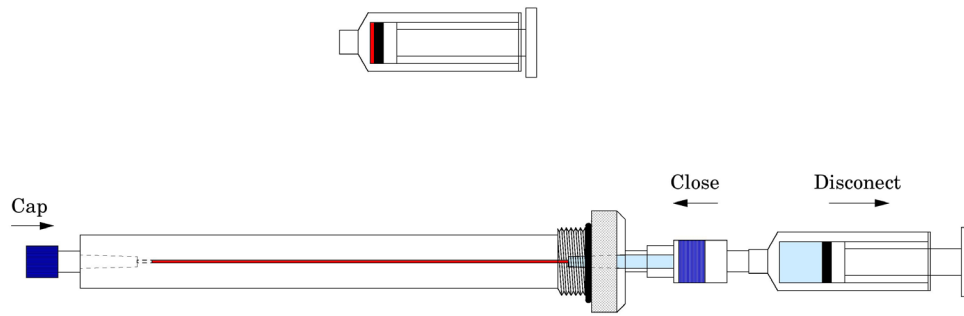

3. Remove the syringe and tightly cap the end and close the valve.

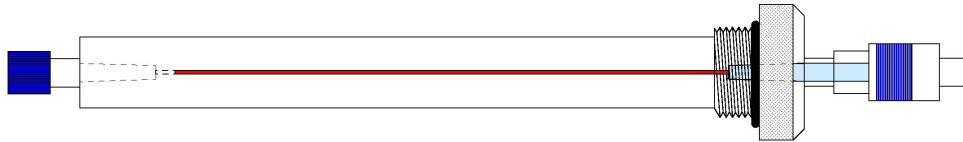

Line source is ready for insertion into the 20cm Tank.

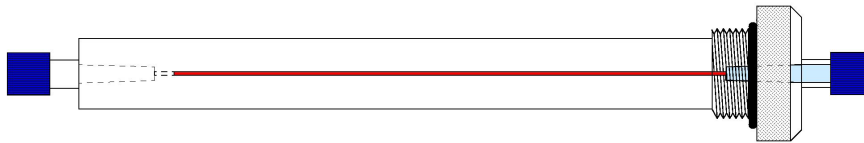

The line source can also be used with two caps instead of the valve.

### Phantom positioning for scanning

The ECT Line Source phantom should be mounted using the case mount system. Place the case on the patient couch as illustrated in the drawing below. Make sure the safety strap is securely attached to the table. Use the rotation radius recommended by NEMA for scanning the phantom. Check that the phantom is level by using the level provided. Position the phantom in the center of the gantry by adjusting the camera head in a lateral position, and moving the table so the center fill plug is at the center of the camera field of view. Be sure that the phantom is rotated so the mount bracket is on top as illustrated. In this position, check that the Line Source phantom is parallel to the collimator. Recheck that the phantom remains level. The image acquisition can now begin.

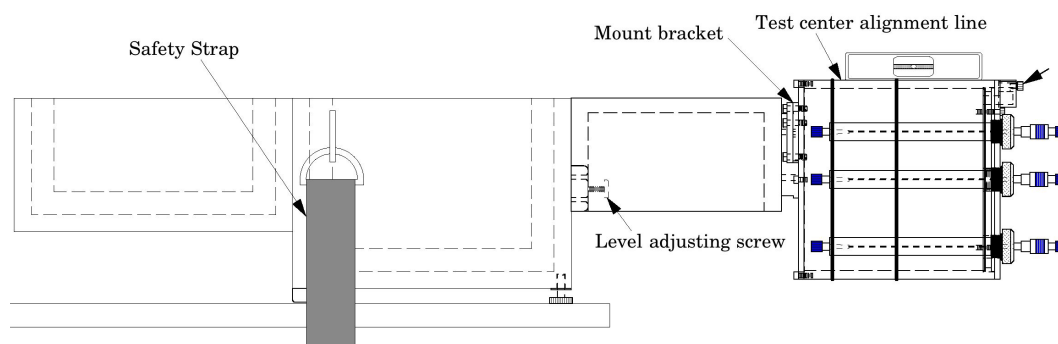

## Bibliography

Graham, Fahey, Madsen

Quantitation of SPECT performance: Report of task group 4, Nuclear Medicine Committee. Medical Physics 1994: 401-410

Goodenough, Atkins, Dyer

Automated Techniques for Quality Assurance of Radiological Image Modalities. SPIE Vol 1444 Image Capture, Formatting, and Display 87-99, 1991

Dyer, Clulow, Frank, Becker

Core Laboratory SPECT QC Validation Program for Multi-Center Clinical Trial. J. Nuc Med, May 1999, Vol:40 pg. 286

Fahey, Graham, Madsen, VanAswegen, Yester

Quantitation of SPECT performance: Report of Task Group 4, Nuclear Medicine Committee.

Med Phys., 22, 1995, 401-409

NEMA Standards Publication Gamma Cameras NU-1 2007

Rosslyn, VA, 22209

Rossman

Point Spread Function, Line Spread Function, and Modulation Transfer Function: Tools for the Study of Imaging Systems, Radiology 93:257-272, August 1969

Hines, Kayayan, Colsher, Hashimoto, Schubert, Fernando, Simcic, Vernon, Sinclair; Recommendations for implementing SPECT instrumentation quality control

Eur J of Nucl Med (1999) 26:527-532

**WARRANTY**

THE PHANTOM LABORATORY INCORPORATED (“Seller”) warrants that this product shall remain in good working order and free of all material defects for a period of one (1) year following the date of purchase. If, prior to the expiration of the one (1) year warranty period, the product becomes defective, Buyer shall return the product to the Seller at:

The Phantom Laboratory Incorporated  
2727 State Route 29  
Greenwich, NY 12834  
or  
PO Box 511  
Salem, NY 12865-0511

Seller shall, at Seller’s sole option, repair or replace the defective product. The Warranty does not cover damage to the product resulting from accident or misuse.

IF THE PRODUCT IS NOT IN GOOD WORKING ORDER AS WARRANTED, THE SOLE AND EXCLUSIVE REMEDY SHALL BE REPAIR OR REPLACEMENT, AT SELLER’S OPTION. IN NO EVENT SHALL SELLER BE LIABLE FOR ANY DAMAGES IN EXCESS OF THE PURCHASE PRICE OF THE PRODUCT. THIS LIMITATION APPLIES TO DAMAGES OF ANY KIND, INCLUDING, BUT NOT LIMITED TO, DIRECT OR INDIRECT DAMAGES, LOST PROFITS, OR OTHER SPECIAL, INCIDENTAL, OR CONSEQUENTIAL DAMAGES, WHETHER FOR BREACH OF CONTRACT, TORT OR OTHERWISE, OR WHETHER ARISING OUT OF THE USE OF OR INABILITY TO USE THE PRODUCT. ALL OTHER EXPRESS OR IMPLIED WARRANTIES, INCLUDING, BUT NOT LIMITED TO, THE IMPLIED WARRANTY OF MERCHANT ABILITY AND FITNESS FOR PARTICULAR PURPOSE, ARE HEREBY DISCLAIMED.